

**臥式冷卻攪拌機**  
HORIZONTAL COOLING BLENDER

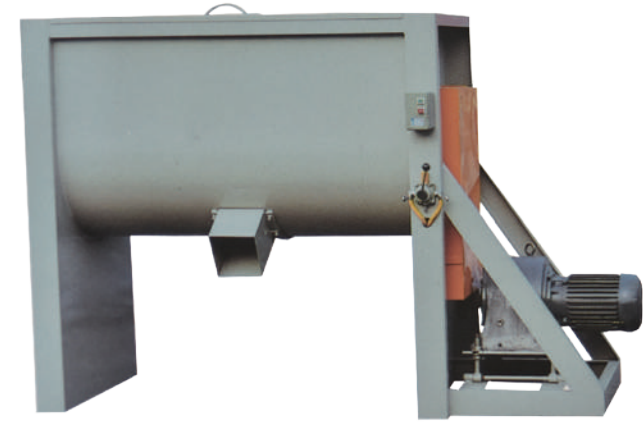

**立式冷卻攪拌機**  
VERTICAL COOLING BLENDER

- 本機的桶身是由雙層不鏽鋼所構成，桶壁中間拉旋轉葉片使冷卻水循環達到散熱效果。
- The barrel is made of double stainless steel jacket. The internal space is with spiral blades for cooling water circulation, to effect heat dissipation.



**行銘機械股份有限公司**  
YEAN HORNG MACHINERY CO., LTD.

71844 台南市關廟區五甲路 240 號  
No.240, Wujia Rd., Guanmiao Dist.,  
Tainan City 71844, Taiwan  
TEL : 886-6-5959875 FAX : 886-6-5952343  
E-mail : yeang.horng@msa.hinet.net  
http://www.yean-horng.com  
統一編號 : 53146671



**行銘機械** 專業的技術·優良的服務  
YEAN HORNG Professional Technique and Excellent Service

**Mixing, Compounding & Extrusion System**

9 SCREWS

**高速混合機 & 立式冷卻攪拌機**  
HIGH-SPEED MIXER & VERTICAL COOLING BLENDER

- 本機內部與外部及所有配管都是不鏽鋼材質。
- 本機的桶蓋都具有安全裝置，只要桶蓋開啟，馬達立即停止運轉。
- Inner and outer of the tank and all the piping fitting are made of stainless steel.
- The Lid is equipped with safety device, motor will stop when Lid is opened.



**實驗室設備**  
Lab Equipment

**10L 高速混合機**  
Lab Equipment For 10 Liter High Speed Mixer



**3L 捏合機**  
Lab Equipment for 3 Liter Kneader

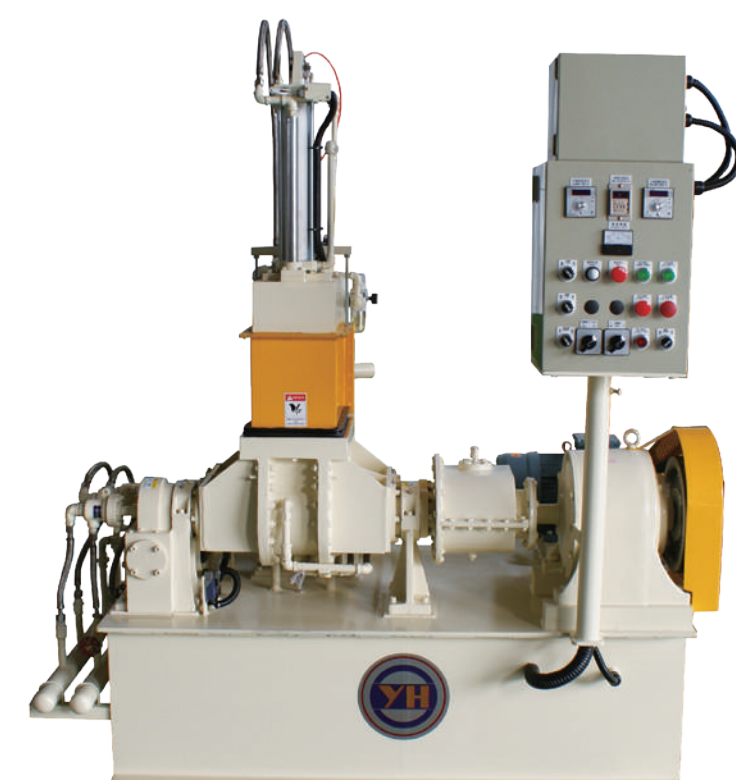

**行星式混練機專供複合材料造粒或出片用生產線**  
Planetary Rolling Mixer For Compound Pellets or Sheets

高產量 低耗能 佔地小 省人力

- The best mixing effect, easy to control the quality.
- Easy to operate, save the labor cost.
- The power consumption will save 40%-50% compared to the traditional equipment.
- Easy to install and maintain & Occupy small space.
- The equipment can be designed and equipped according to different running materials. Such as Soft PVC, Rigid PVC, Transparent PVC, EVA Base Non Halogen Compound, TPR, TPU, Sulfur Compound, CaCo3 High Filler Compound and Most Thermoplastics of Master Batch Compound.

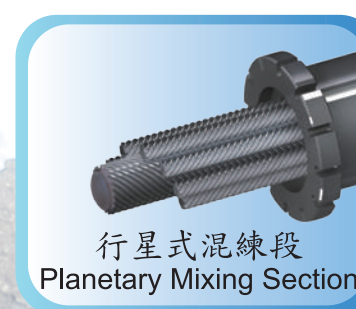

**冷卻震動篩選機**  
COOLING VIBRATION SCREEN

- 特點：
1. 具大顆粒、良品與微粉高效率三級篩選。
  2. 篩面積廣，冷風擴散佳，冷卻時效高。
  3. 整體結構平穩，篩網一體成型，故低噪音與耐用性佳。
  4. 易清料、清潔與維護，毋需工具拆卸。
- Feature:
1. Separating size of pellet and dust efficiently.
  2. Large cooling area and more cooling efficiently.
  3. Stable structure and one shape screen is durable and low noise.
  4. Easy to maintain and clean material without tools.

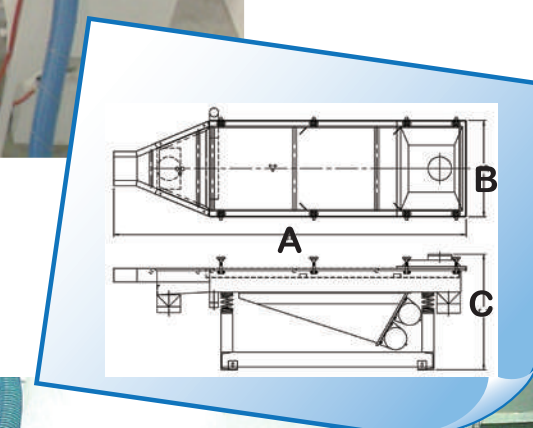

冷卻振動篩選機適用於各種粒體製造，產品之冷卻與顆粒大小分級篩選。  
Cooling Vibration Screen is used for cooling and separating different size of pellet in all kind of pellet manufactory.

Model	Cooling Fan	Capacity	Size A	Size B	Size C
CVS-2000	2 HP	150kg / hr	2200 mm	820 mm	923 mm
CVS-3000	2 HP	250kg / hr	3300 mm	820 mm	983 mm
CVS-4000	2 HP	500kg / hr	4000 mm	820 mm	983 mm
CVS-4000A	3 HP	800kg / hr	4000 mm	1042mm	993 mm

**重量式配方計量機**  
GRAVIMETRIC FORMULA WEIGHING UNIT

本設備適用於注塑、擠出、壓塑及吹塑成型機。對流動性良好之原料進行批次計量及均勻攪拌混合。The Weighing Unit is suited for using on injection molding, extrusion and blow molding machines. It's designed for the accurate dosing, weighing and blending of free-flowing material.

- 特點：
- 模組化設計，所佔空間小。
  - 配方可依重量或其百分比二種模式設定。
  - 磅桶及攪拌槽，清潔、保養容易。
  - 彩色觸控螢幕，操作簡便。
  - 批次計量精確度可達±0.2%以內。
- Feature:
- \* Modular design, space saving.
  - \* The formulations setting by weight mode or percentage mode.
  - \* Easy cleaning and maintenance of weight bin and mixing chamber.
  - \* Colorful touch screen, easy operation.
  - \* The batch measurement accuracy within ±0.2%.

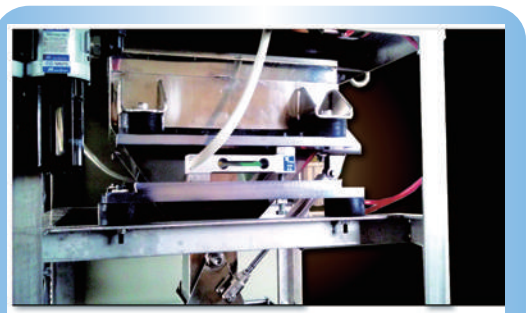

特殊防震計量單元，計量精度穩定。  
Special anti-vibration measurement unit, measurement accuracy & stability.



混合槽及攪拌葉片換料清潔便利，並設置安全開關。  
Easy clean out on the mixing chamber & mixer. Safety switch install on the door.

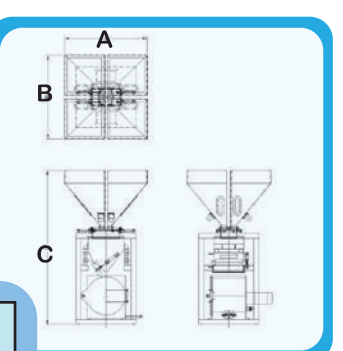
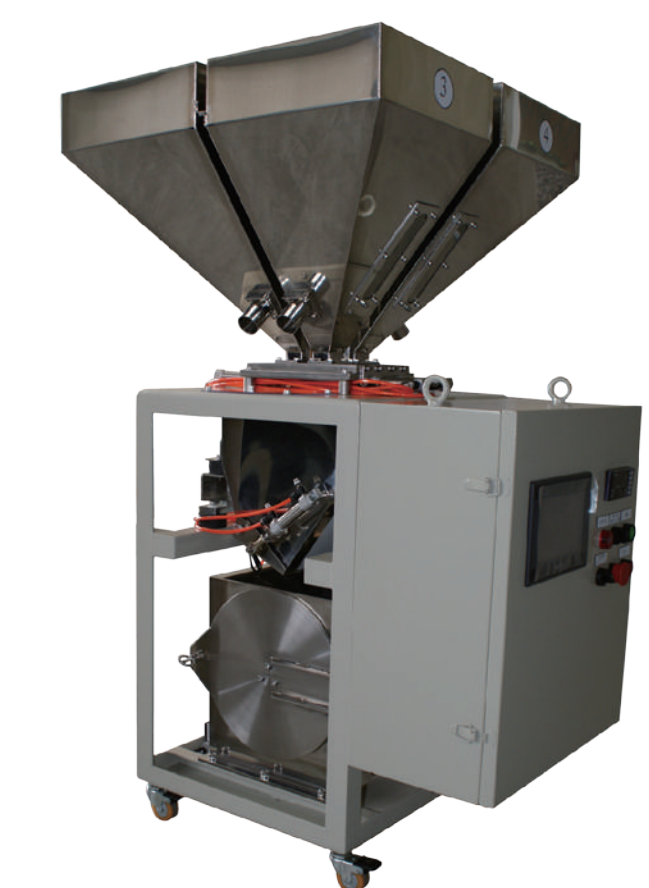

Model	Capacity	Nos Of Component	Size A	Size B	Size C
GFW-250	250Kg/Hr	2~6	641 mm	651 mm	1197 mm
GFW-500	500Kg/Hr	2~6	661 mm	661 mm	1422 mm